

Technical Data for Alicat **WHISPER** Mass Flow Meters

0 – 0.5 sccm Full Scale through 0 – 500 slpm Full Scale



Tel: 888-290-6060

www.alicat.com/whisper

Alicat Whisper mass flow meters are designed for low pressure drop applications. Whisper offers the lowest pressure drop available for mass flow metering or control on the market today.

Standard Specifications (Contact Alicat for available options.)

Performance	Whisper Mass Flow Meter
Accuracy at calibration conditions after tare	± (0.8% of Reading + 0.2% of Full Scale)
High Accuracy at calibration conditions after tare	± (0.4% of Reading + 0.2% of Full Scale) High Accuracy option not available for units ranged under 5 sccm or over 500 slpm.
Accuracy for Bidirectional Meters at calibration conditions after tare	± (0.8% of reading + 0.2% of total span from positive full scale to negative full scale)
Repeatability	± 0.2% Full Scale
Zero Shift and Span Shift	0.02% Full Scale / °Celsius / Atm
Operating Range / Turndown Ratio	0.5% to 100% Full Scale / 200:1 Turndown
Maximum Measurable Flow Rate	128% Full Scale
Typical Response Time	10 ms (Adjustable)
Warm-up Time	< 1 Second

Operating Conditions	Whisper Mass Flow Meter
Mass Reference Conditions (STP)	25°C & 14.696 psia (standard — others available on request)
Operating Temperature	-10 to +60 °Celsius
Humidity Range (Non-Condensing)	0 to 100%
Maximum Internal Pressure (Static)	45 psig
Maximum Allowable Instantaneous Differential Pressure Across Device (Inlet to Outlet)	15 psid
Proof Pressure	175 psig
Mounting Attitude Sensitivity	None
Ingress Protection	IP40
Wetted Materials	303 & 302 Stainless Steel, Viton®, Heat Cured Silicone Rubber, Glass Reinforced Polyphenylene Sulfide, Heat Cured Epoxy, Aluminum, Gold, Silicon, Glass. If your application demands a different material, please contact Alicat.

Communications / Power	Whisper Mass Flow Meter
Monochrome LCD or Color TFT Display with integrated touchpad	Simultaneously displays Mass Flow, Volumetric Flow, Pressure and Temperature
Digital Output Signal ¹ Options	RS-232 Serial / RS-485 Serial / Modbus / PROFIBUS ³
Analog Output Signal ² Options	0-5 Vdc / 1-5 Vdc / 0-10 Vdc / 4-20 mA
Optional Secondary Analog Output Signal ²	0-5 Vdc / 1-5 Vdc / 0-10 Vdc / 4-20 mA
Electrical Connection Options	8 Pin Mini-DIN / 9-pin D-sub (DB9) / 15-pin D-sub (DB15) / 6 pin locking
Supply Voltage	7 to 30 Vdc (15-30 Vdc for 4-20 mA outputs)
Supply Current	0.040 Amp (+ output current on 4-20 mA)

1. The **Digital Output Signal** communicates Mass Flow, Volumetric Flow, Pressure and Temperature
2. The **Analog Output Signal** and **Optional Secondary Analog Output Signal** communicate your choice of Mass Flow, Volumetric Flow, Pressure or Temperature
3. If selecting **PROFIBUS**, no analog signal is available. See PROFIBUS specifications for supply voltages and currents (www.alicat.com/profibus). PROFIBUS units do not have the display.

Features	Whisper Mass Flow Meter
Gas Select™ 5.0	Gas Select™ 5.0 provides 98 Preloaded Gas Calibrations: See the following page for a complete list. If your application calls for a gas not on this list, please let us know. We can also calibrate to a wide variety of complex gas mixtures involving up to eight gas constituents.
COMPOSER™	COMPOSER™ is a feature of Gas Select™ 5.0 that allows users to defines up to 20 user gas compositions with up to 5 constituent gases per mix (www.alicat.com/composer).

Range Specific Specifications

Full Scale Flow Mass Meter	Pressure Drop at FS Flow (psid) venting to atmosphere	Mechanical Dimensions	Process Connections ¹
0.5 sccm to 2 sccm	0.06	3.9"H x 2.4"W x 1.1"D	M-5 (10-32) Female Thread (Shipped with M-5 (10-32) Male Buna-N O-ring face seal to 1/8" Female NPT fittings.)
5 sccm to 20 sccm	0.07		
50 sccm	0.07		
100 sccm to 200 sccm	0.06	4.1"H x 2.4"W x 1.1"D	1/8" NPT Female
500 sccm	0.07		
1 slpm to 5 slpm	0.07		
10 slpm	0.08	4.3"H x 2.7"W x 1.1"D	1/4" NPT Female
20 slpm	0.25	4.4"H x 4.0"W x 1.6"D	
40 slpm	0.12	5.0"H x 4.0"W x 1.6"D	1/2" NPT Female
50 slpm	0.14	5.0"H x 4.0"W x 1.6"D	3/4" NPT Female
100 slpm	0.24		
250 slpm	0.60		
500 slpm	0.39	5.3"H x 5.2"W x 2.9"D	3/4" NPT Female

1. Compatible with Beswick®, Swagelok® tube, Parker®, face seal, push connect and compression adapter fittings. VCR and SAE connections upon request.

Alicat Gas Select™ 5.0 Preloaded Gases

PURE NON-CORROSIVE GASES		
Gas Number	Short Name	Long Name
14	C2H2	Acetylene
0	Air	Air
1	Ar	Argon
16	i-C4H10	i-Butane
13	n-C4H10	n-Butane
4	CO2	Carbon Dioxide
3	CO	Carbon Monoxide
60	D2	Deuterium
5	C2H6	Ethane
15	C2H4	Ethylene (Ethene)
7	He	Helium
6	H2	Hydrogen
17	Kr	Krypton
2	CH4	Methane
10	Ne	Neon
8	N2	Nitrogen
9	N2O	Nitrous Oxide
11	O2	Oxygen
12	C3H8	Propane
19	SF6	Sulfur Hexafluoride
18	Xe	Xenon

BREATHING GASES		
Gas Number	Short Name	Long Name
164	EAN-32	32% O2 / 68% N2
165	EAN	36% O2 / 64% N2
166	EAN-40	40% O2 / 60% N2
167	HeOx-20	20% O2 / 80% He
168	HeOx-21	21% O2 / 79% He
169	HeOx-30	30% O2 / 70% He
170	HeOx-40	40% O2 / 60% He
171	HeOx-50	50% O2 / 50% He
172	HeOx-60	60% O2 / 40% He
173	HeOx-80	80% O2 / 20% He
174	HeOx-99	99% O2 / 1% He
175	EA-40	Enriched Air-40% O2
176	EA-60	Enriched Air-60% O2
177	EA-80	Enriched Air-80% O2
178	Metabol	Metabolic Exhalant (16% O2 / 78.04% N2 / 5% CO2 / 0.96% Ar)

CHROMATOGRAPHY GASES		
Gas Number	Short Name	Long Name
29	P-5	5% CH4 / 95% Ar
206	P-10	10% CH4 / 90% Ar

WELDING GASES		
Gas Number	Short Name	Long Name
23	C-2	2% CO2 / 98% Ar
22	C-8	8% CO2 / 92% Ar
21	C-10	10% CO2 / 90% Ar
140	C-15	15% CO2 / 85% Ar
141	C-20	20% CO2 / 80% Ar
20	C-25	25% CO2 / 75% Ar
142	C-50	50% CO2 / 50% Ar
24	C-75	75% CO2 / 25% Ar
25	He-25	25% He / 75% Ar
143	He-50	50% He / 50% Ar
26	He-75	75% He / 25% Ar
144	He-90	90% He / 10% Ar
27	A1025	90% He / 7.5% Ar / 2.5% CO2
28	Star29	Stargon CS 90% Ar / 8% CO2 / 2% O2

PURE CORROSIVES*		
Gas Number	Short Name	Long Name
32	NH3	Ammonia
80	1Butene	Butylene (1-Butene)
81	cButene	Cis-Butene (cis-2-butene)
82	iButene	Iso-Butene
83	tButene	Trans-Butene
84	COS	Carbonyl Sulfide
33	Cl2	Chlorine
85	CH3OCH3	Dimethylether
34	H2S	Hydrogen Sulfide (H2S)
31	NF3	NF3 (Nitrogen Trifluoride)
30	NO	NO (Nitric Oxide)
36	C3H6	Propylene (Propylene)
86	SiH4	Silane (SiH4)
35	SO2	Sulfur Dioxide

*Pure Corrosive gases are only available on S-Series instruments that are compatible with these gases.
Gas numbers 33 and 35 are not available on controllers.

BIOREACTOR GASES		
Gas Number	Short Name	Long Name
145	Bio-5M	5% CH4 / 95% CO2
146	Bio-10M	10% CH4 / 90% CO2
147	Bio-15M	15% CH4 / 85% CO2
148	Bio-20M	20% CH4 / 80% CO2
149	Bio-25M	25% CH4 / 75% CO2
150	Bio-30M	30% CH4 / 70% CO2
151	Bio-35M	35% CH4 / 65% CO2
152	Bio-40M	40% CH4 / 60% CO2
153	Bio-45M	45% CH4 / 55% CO2
154	Bio-50M	50% CH4 / 50% CO2
155	Bio-55M	55% CH4 / 45% CO2
156	Bio-60M	60% CH4 / 40% CO2
157	Bio-65M	65% CH4 / 35% CO2
158	Bio-70M	70% CH4 / 30% CO2
159	Bio-75M	75% CH4 / 25% CO2
160	Bio-80M	80% CH4 / 20% CO2
161	Bio-85M	85% CH4 / 15% CO2
162	Bio-90M	90% CH4 / 10% CO2
163	Bio-95M	95% CH4 / 5% CO2

LASER GASES		
Gas Number	Short Name	Long Name
179	LG-4.5	4.5% CO2 / 13.5% N2 / 82% He
180	LG-6	6% CO2 / 14% N2 / 80% He
181	LG-7	7% CO2 / 14% N2 / 79% He
182	LG-9	9% CO2 / 15% N2 / 76% He
183	HeNe-9	9% Ne / 91% He
184	LG-9.4	9.4% CO2 / 19.25% N2 / 71.35% He

O2 CONCENTRATOR GASES		
Gas Number	Short Name	Long Name
197	OCG-89	89% O2 / 7% N2 / 4% Ar
198	OCG-93	93% O2 / 3% N2 / 4% Ar
199	OCG-95	95% O2 / 1% N2 / 4% Ar

REFRIGERANTS*		
Gas Number	Short Name	Long Name
100	R-11	Trichlorofluoromethane
101	R-115	Chloropentafluoroethane
102	R-116	Hexafluoroethane
103	R-124	Chlorotetrafluoroethane
104	R-125	Pentafluoroethane
105	R-134A	Tetrafluoroethane
106	R-14	Tetrafluoromethane
107	R-142b	Chlorodifluoroethane
108	R-143a	Trifluoroethane
109	R-152a	Difluoroethane
110	R-22	Difluoromonochloromethane
111	R-23	Trifluoromethane
112	R-32	Difluoromethane
113	RC-318	Octafluorocyclobutane
114	R-404A	44% R-125 / 4% R-134A / 52% R-143A
115	R-407C	23% R-32 / 25% R-125 / 52% R-134A
116	R-410A	50% R-32 / 50% R-125
117	R-507A	50% R-125 / 50% R-143A

*Refrigerant gases are only available on S-Series instruments that are compatible with these gases.

FUEL GASES		
Gas Number	Short Name	Long Name
185	Syn Gas-1	40% H2 + 29% CO + 20% CO2 + 11% CH4
186	Syn Gas-2	64% H2 + 28% CO + 1% CO2 + 7% CH4
187	Syn Gas-3	70% H2 + 4% CO + 25% CO2 + 1% CH4
188	Syn Gas-4	83% H2 + 14% CO + 3% CH4
189	Nat Gas-1	93% CH4 / 3% C2H6 / 1% C3H8 / 2% N2 / 1% CO2
190	Nat Gas-2	95% CH4 / 3% C2H6 / 1% N2 / 1% CO2
191	Nat Gas-3	95.2% CH4 / 2.5% C2H6 / 0.2% C3H8 / 0.1% C4H10 / 1.3% N2 / 0.7% CO2
192	Coal Gas	50% H2 / 35% CH4 / 10% CO / 5% C2H4
193	Endo	75% H2 + 25% N2
194	HHO	66.67% H2 / 33.33% O2
195	HD-5	LPG 96.1% C3H8 / 1.5% C2H6 / 0.4% C3H6 / 1.9% n-C4H10
196	HD-10	LPG 85% C3H8 / 10% C3H6 / 5% n-C4H10

STACK GASES		
Gas Number	Short Name	Long Name
200	FG-1	2.5% O2 / 10.8% CO2 / 85.7% N2 / 1% Ar
201	FG-2	2.9% O2 / 14% CO2 / 82.1% N2 / 1% Ar
202	FG-3	3.7% O2 / 15% CO2 / 80.3% N2 / 1% Ar
203	FG-4	7% O2 / 12% CO2 / 80% N2 / 1% Ar
204	FG-5	10% O2 / 9.5% CO2 / 79.5% N2 / 1% Ar
205	FG-6	13% O2 / 7% CO2 / 79% N2 / 1% Ar

WHISPER MW

- 0 – 0.5 sccm
- 0 – 1 sccm
- 0 – 2 sccm
- 0 – 5 sccm
- 0 – 10 sccm
- 0 – 20 sccm

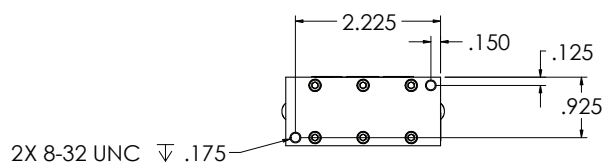
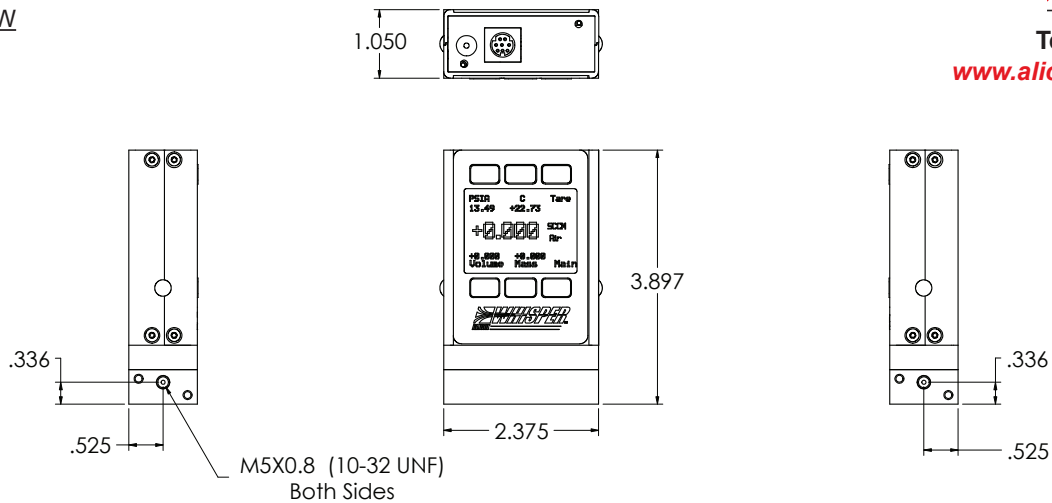

MW 0.5 sccm to 20 sccm approximate shipping weight: 0.8lb

WHISPER MW

- 0 – 50 sccm
- 0 – 100 sccm
- 0 – 200 sccm
- 0 – 500 sccm
- 0 – 1 slpm
- 0 – 2 slpm
- 0 – 5 slpm

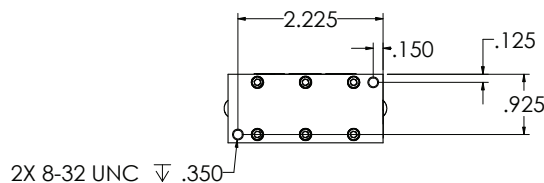
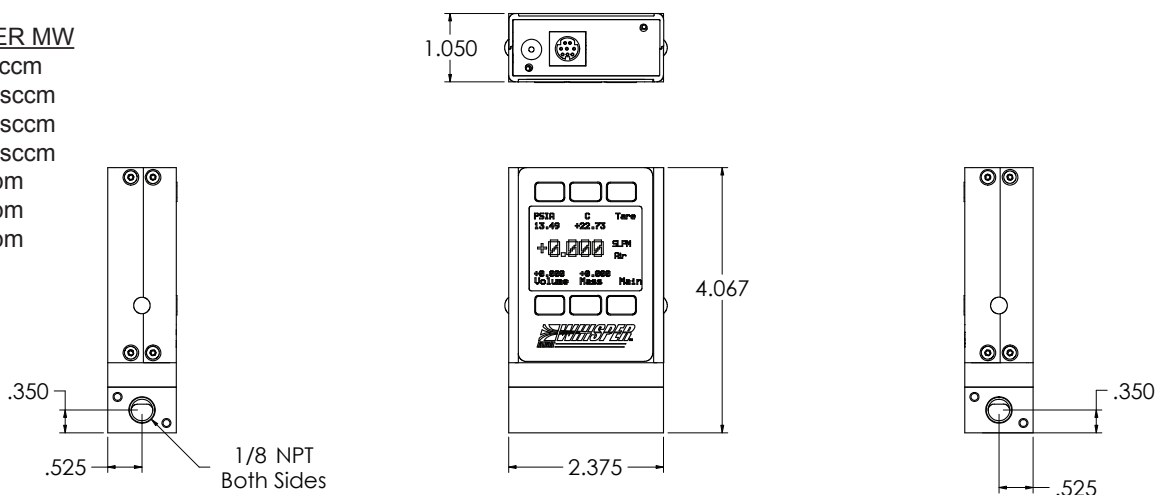

MW 50 sccm to 5 slpm approximate shipping weight: 1.0lb

WHISPER MW

- 0 – 10 slpm

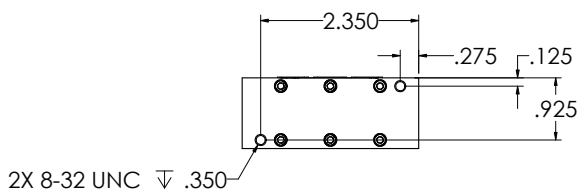
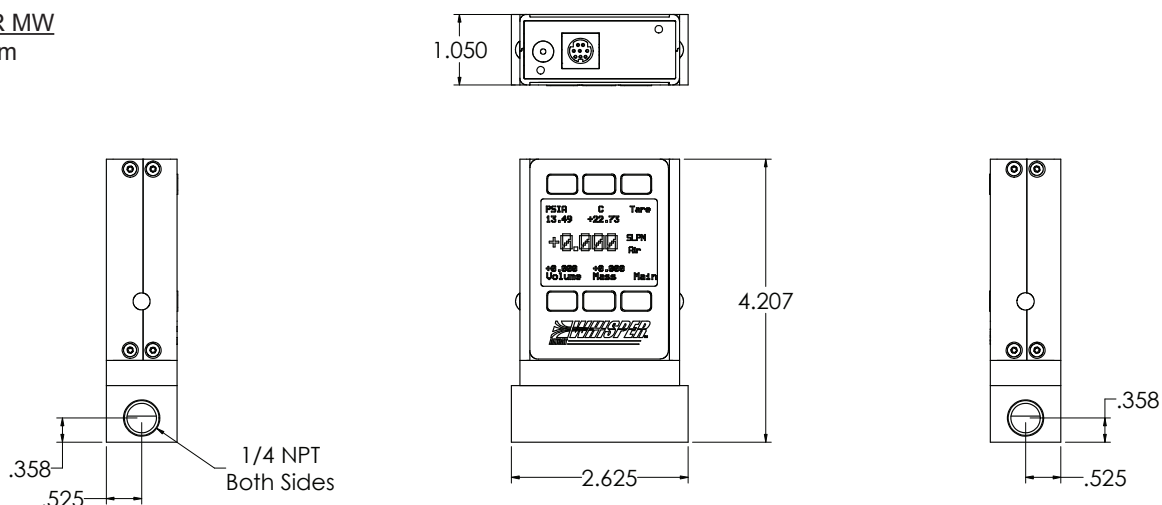

MW 10 slpm approximate shipping weight: 1.4 lb.

WHISPER MW
0 – 20 slpm

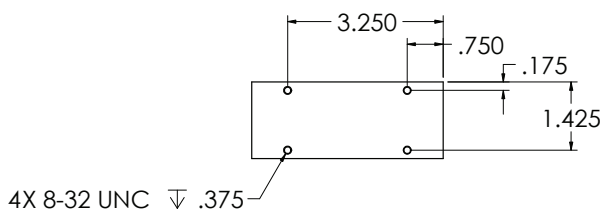
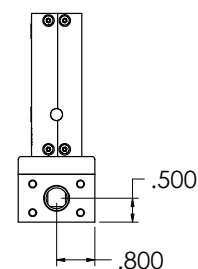
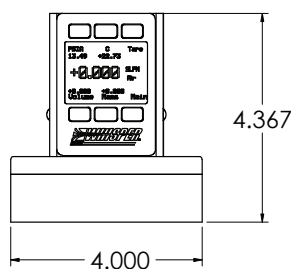
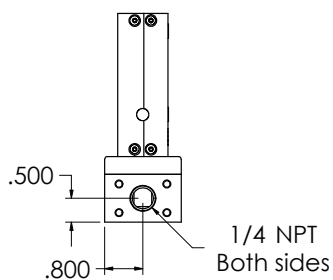
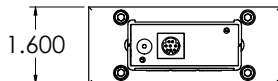

MW 20 slpm approximate shipping weight: 2.4 lb.

WHISPER MW
0 – 40 slpm

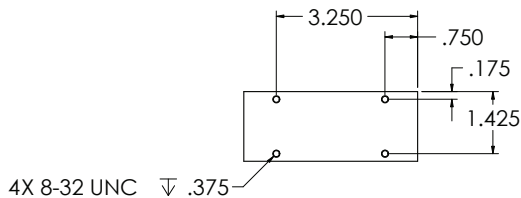
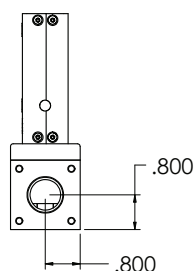
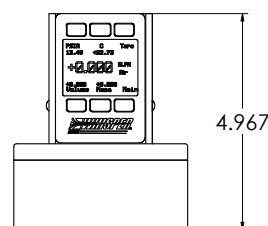
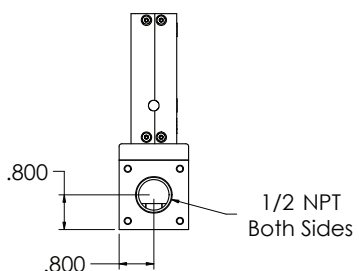
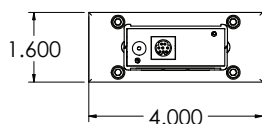

MW 40 slpm approximate shipping weight: 3.2 lb.

WHISPER MW
0 – 50 slpm
0 – 100 slpm
0 – 250 slpm

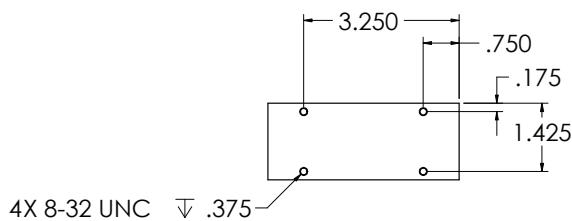
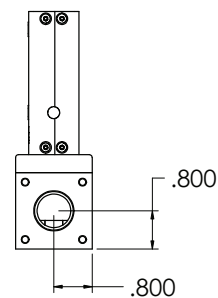
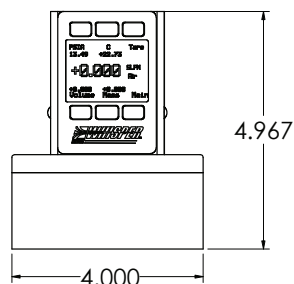
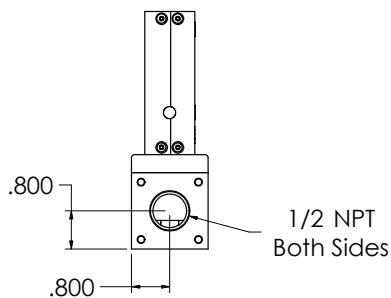
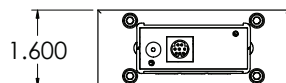

MW 50 slpm to 250 slpm approximate shipping weight: 3.5lb

WHISPER MW
0 – 500 slpm

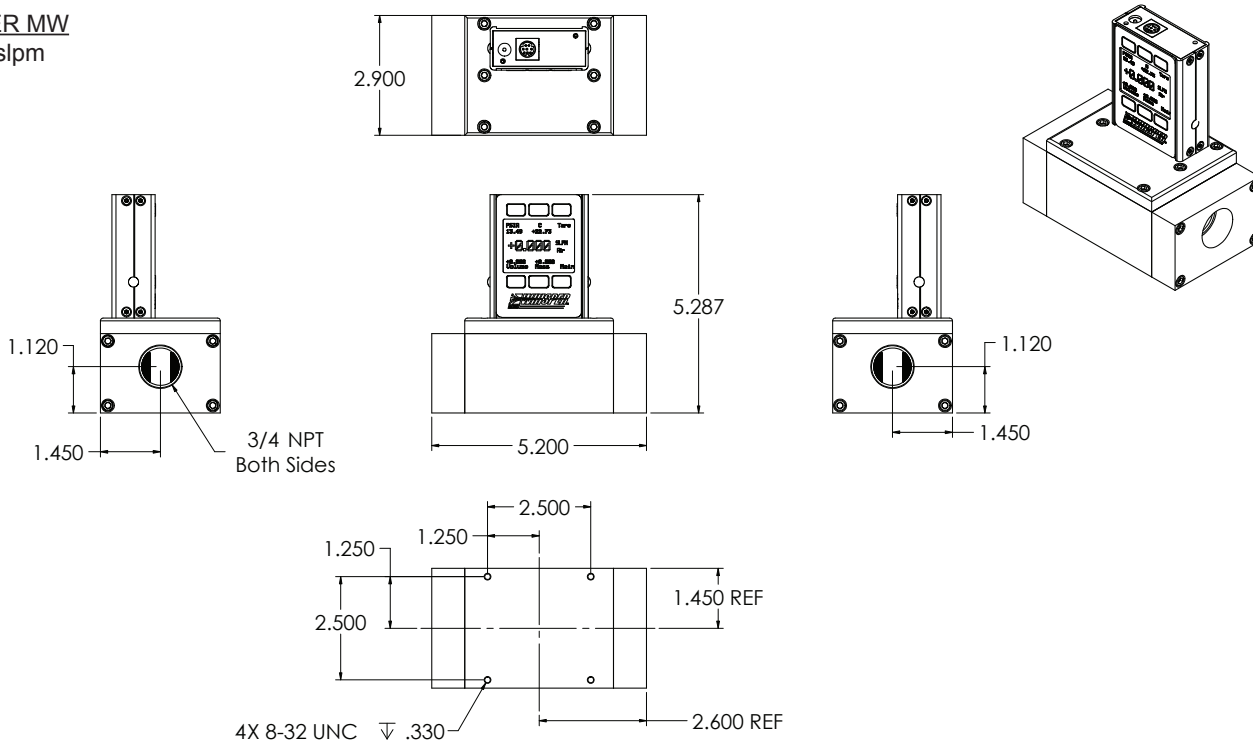

MW 500 slpm approximate shipping weight: 4.5lb